

DESCRIPTION

The UCAN heavy load expansion anchor is a mechanical anchor with controlled expansion that displays exceptionally high tension and shear loads. This anchor is ideal for applications requiring a high degree of security and reliability.

FEATURES

- Superior for dynamic and static loads
- Torque controlled expansion
- High shear load
- Four slot expansion sleeve ensures excellent load transfer
- Through fastening
- Collapsible collar provides reliable pull-down force

LIMITATIONS

Not recommended for uncured concrete (less than 7 days old), light-weight concrete, masonry block or brick.

TYPICAL APPLICATIONS

- Structural steel columns and frames
- Machinery and equipment installation
- Vibratory loading applications
- Parking structure rehabilitation
- Road and bridge construction
- Crane, conveyor installation
- Robotics
- Seismic anchoring

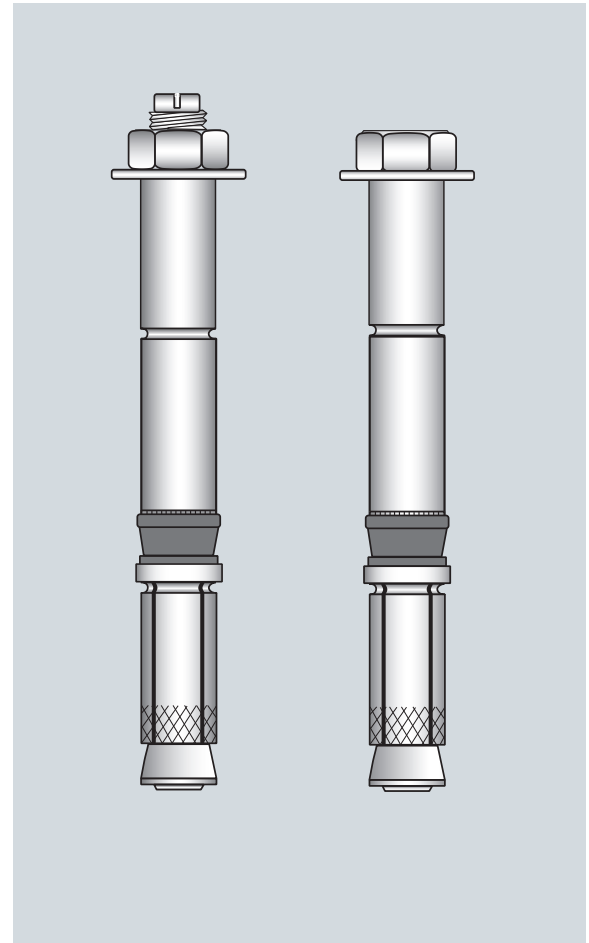

MATERIAL SPECIFICATIONS

Anchor Component	Material Standard	Mechanical Properties	
		F _u	F _y
Carbon steel hex-head bolt	DIN 931; Class 8.8	800 MPa (116 ksi)	640 MPa (93 ksi)
Carbon steel threaded stud	DIN 13-6; Class 8.8	800 MPa (116 ksi)	640 MPa (93 ksi)
Stainless steel hex head bolt	DIN 931; Grade A4/316, Class 70	700 MPa (102 ksi)	450 MPa (65 ksi)
Stainless steel threaded stud	DIN ISO 3506; Grade A4/316, Class 70	700 MPa (116 ksi)	450 MPa (65 ksi)
Collapsible collar	-	Polyethylene	
Corrosion protection	DIN ISO 4042	≥5µm, zinc plated and yellow passivated	

HEAVY LOAD EXPANSION ANCHOR

ANCHOR SELECTION

Part Number				Bolt/Stud	Drill Bit/ Anchor	Anchor Length		Maximum Thickness	Box Quantity
LHL	LHS	BHL	BHS	diameter	diameter	LHL/LHS	BHL/BHS		
				mm	mm	mm	mm		
LHL600		BHL600				55	60	0	100
LHL610	LHS610	BHL610	BHS610			65	70	10	50
LHL625	LHS625	BHL625	BHS625	6	10	80	85	25	50
LHL650	LHS650	BHL650	BHS650			100	110	50	25
LHL6100		BHL6100				100	110	50	25
LHL800		BHL800				65	75	0	50
LHL810	LHS810	BHL810	BHS810			75	85	10	50
LHL825	LHS825	BHL825	BHS825	8	12	90	100	25	50
LHL850	LHS850	BHL850	BHS850			115	125	50	25
LHL8100		BHL8100				160	170	50	25
LHL1000		BHL1000				75	90	0	25
LHL1010	LHS1010	BHL1010	BHS1010			85	100	10	25
LHL1025	LHS1025	BHL1025	BHS1025	10	14	100	115	25	25
LHL1050	LHS1050	BHL1050	BHS1050			125	140	50	25
LHL1075		BHL1075				150	165	75	25
LHL10100		BHL10100				170	185	100	25
LHL1200		BHL1200				95	110	0	20
LHL1215	LHS1215	BHL1215	BHS1215			105	120	15	20
LHL1225	LHS1225	BHL1225	BHS1225	12	18	115	130	25	20
LHL1240	LHS1240	BHL1240	BHS1240			130	145	40	20
LHL1270		BHL1270				160	175	70	20
LHL12100		BHL12100				190	205	100	10
LHL1600		BHL1600				110	135	0	10
LHL1625	LHS1625	BHL1625	BHS1625	16	24	140	160	25	10
LHL1650	LHS1650	BHL1650	BHS1650			160	180	50	10
LHL16100		BHL16100				210	230	100	5
LHL2000		BHL2000				140	165	0	10
LHL2030	LHS2030	BHL2030	BHS2030	20	28	170	190	30	10
LHL2060	LHS2060	BHL2060	BHS2060			200	220	60	5
LHL20100		BHL20100				240	260	100	5

INSTALLATION

Setting Details	Anchor bolt/ threaded rod diameter (mm)						
		6	8	10	12	16	20
Bolt / rod dia.	d_a	6	8	10	12	16	20
Nom. drill bit dia.	d_0	10	12	14	18	24	28
Hole depth	h_l	60	70	85	100	125	150
Effective embedment	h_{ef}	45	55	65	80	100	125
Min. concrete thickness	h	120	140	165	200	235	300
Max.hole size in fixture	d_c	12	14	16	20	26	31
Installation torque [N. m]	T_{inst}	10	25	50	80	200	400
Allowable bending moment [N. m]	M_{rec}	7	17.1	34.2	60.0	152	297
	M_{rec}	4.9	12.1	24.1	42.1	107	209
Anchor spacing	s	135	165	195	240	300	375
	s_{min}	45	55	65	80	100	125
Edge distance	c	115	135	175	200	250	315
	c_{min}	45	55	65	80	100	125

Note: I./ Metric size carbide drill bit shall conform to DIN 8035

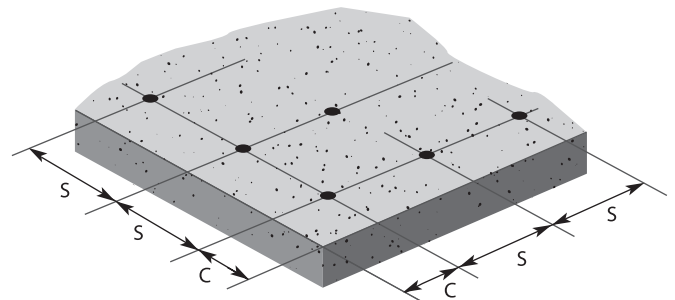
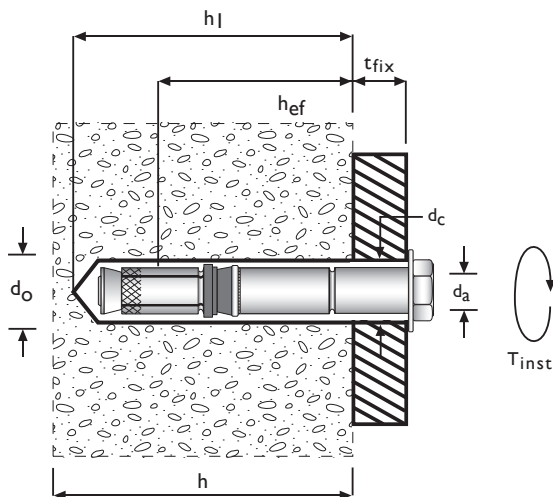
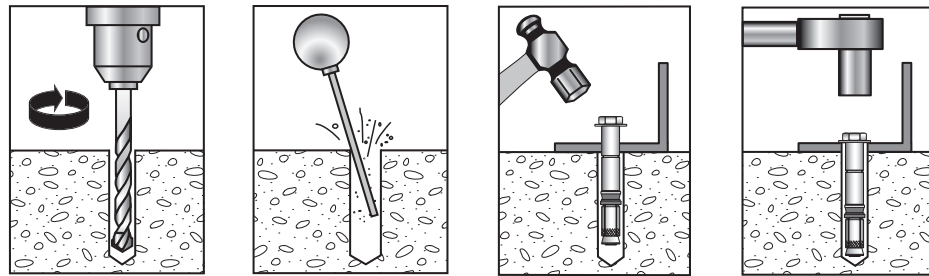

HEAVY LOAD EXPANSION ANCHOR

DESIGN DATA

Ultimate Tension and Shear Loads Normal weight stone aggregate concrete

Anchor dia(mm)	Drill hole dia. mm	Embedment mm	3000psi (21 MPa)		4000psi (28 MPa)		6500psi (45 MPa)	
			Tension	Shear	Tension	Shear	Tension	Shear
			lbf (kN)	lbf (kN)	lbf (kN)	lbf (kN)	lbf (kN)	lbf (kN)
6	10	45	3,581 (16.1)	5,331 (23.8)	4,165 (18.6)	5,604 (24.9)	4,165 (18.6)	5,604 (24.9)
8	12	55	5,005 (22.4)	8,064 (35.7)	5,821 (25.9)	8,481 (37.8)	7,798 (34.7)	9,489 (42.4)
10	14	65	7,038 (31.2)	12,495 (55.7)	8,183 (36.4)	13,139 (58.5)	10,966 (48.7)	14,704 (65.5)
12	18	80	9,860 (43.8)	18,333 (81.6)	11,463 (51.1)	19,278 (85.8)	15,362 (68.3)	21,571 (95.9)
16	24	100	18,270 (81.2)	31,878 (141.8)	21,245 (94.5)	33,520 (168.0)	28,480 (126.7)	37,510 (167.0)
20	28	125	21,854 (97.3)	42,354 (188.3)	25,410 (113.1)	42,833 (198.1)	34,048 (151.6)	49,833 (221.6)

Allowable Tension and Shear Loads Normal weight stone aggregate concrete

Anchor dia(mm)	Drill hole dia. mm	Embedment mm	3000psi (21 MPa)		4000psi (28 MPa)		6500psi (45 MPa)	
			Tension	Shear	Tension	Shear	Tension	Shear
			lbf (kN)	lbf (kN)	lbf (kN)	lbf (kN)	lbf (kN)	lbf (kN)
6	10	45	1,023 (4.6)	1,523 (6.8)	1,190 (5.3)	1,601 (7.1)	1,190 (5.3)	1,601 (7.1)
8	12	55	1,430 (6.4)	2,304 (10.2)	1,663 (7.4)	2,423 (10.8)	2,228 (9.9)	2,711 (12.1)
10	14	65	2,011 (8.9)	3,570 (15.9)	2,338 (10.4)	3,754 (16.7)	3,133 (13.9)	4,201 (18.7)
12	18	80	2,817 (12.5)	5,238 (23.3)	3,275 (14.6)	5,508 (24.5)	4,389 (19.5)	6,163 (27.4)
16	24	100	5,220 (23.2)	9,108 (40.5)	6,070 (27.0)	9,577 (48.0)	8,137 (36.2)	10,717 (47.7)
20	28	125	6,244 (27.8)	12,101 (53.8)	7,260 (32.3)	12,238 (56.6)	9,728 (43.3)	14,238 (63.3)

DESIGN DATA

**Load Adjustment Factors
– Spacing –**

Anchor in Tension & Shear						
Spacing (mm)	Anchor Size					
	6	8	10	12	16	20
45	0.70					
55	0.73	0.70				
65	0.77	0.73	0.70			
80	0.82	0.77	0.74	0.70		
100	0.88	0.82	0.78	0.74	0.70	
125	0.97	0.89	0.84	0.78	0.74	0.70
135	1.00	0.96	0.86	0.80	0.75	0.71
150		1.00	0.92	0.83	0.78	0.73
175			0.95	0.88	0.81	0.76
200			1.00	0.93	0.85	0.79
250				1.00	0.93	0.85
300					1.00	0.91
350						0.97
375						1.00

**Load Adjustment Factors
– Edge Distance –**

Anchor in Tension							Anchor in Shear							
Edge Distance mm	Anchor Size						Edge Distance mm	Anchor Size						
	6	8	10	12	16	20		6	8	10	12	16	20	
45	0.70						45	0.30						
55	0.74	0.70					55	0.40	0.30					
65	0.79	0.74	0.70				65	0.51	0.39	0.30				
80	0.84	0.79	0.75	0.70			80	0.68	0.52	0.41	0.30			
100	0.94	0.86	0.81	0.75	0.70		100	0.87	0.68	0.55	0.42	0.30		
115	1.00	0.92	0.85	0.78	0.73		115	1.00	0.82	0.66	0.51	0.37		
125	1.00	0.95	0.88	0.81	0.75	0.70	125		0.90	0.73	0.58	0.42	0.30	
135		1.00	0.92	0.84	0.77	0.72	135		1.00	0.82	0.60	0.47	0.35	
150			0.96	0.88	0.80	0.74	150			0.93	0.71	0.54	0.40	
175			1.00	0.96	0.85	0.78	175			1.00	0.87	0.65	0.44	
200				1.00	0.90	0.82	200				1.00	0.77	0.58	
250					1.00	0.90	250					1.00	0.77	
300						0.98	300						0.96	
315						1.00	315						1.00	

HEAVY LOAD EXPANSION ANCHOR

SPECIFICATION

Expansion anchors shall be UCAN Heavy Load Anchors, sizes supplied by Ucan Fastening Products. Anchors shall have torque controlled expansion mechanism, and shall have a plastic compression ring for positive pull-down action. Carbon steel anchors shall be zinc dichromate plated to a minimum thickness of 5 microns and shall have an DIN 931/ DIN 13-6, Grade 8.8 (ASTM A325M equivalent) anchor bolt/stud. Anchors shall be installed according to the manufacturer's published instructions.

Stainless steel expansion anchors shall be UCAN Heavy Load Anchors, supplied by Ucan Fastening Products. Anchors shall have torque controlled expansion mechanism, and shall have a plastic compression ring for positive pull-down action. The anchors shall have an DIN 931/ DIN ISO 3506, Grade A4-70 (ASTM F738M Grade A4-70, 316 alloy equivalent) bolt/stud. Anchors shall be installed according to the manufacturer's published instructions.