

**DESCRIPTION**

The UCAN Hammer Cap is a new type of adhesive capsule for threaded rod and rebar dowelling that combines all the inherent safety and reliability of the capsule system with much easier and faster installation procedures. Thorough mixing of the components is accomplished by simply driving the dowel or rod directly through the capsule. Since no rotation of the rod is required during installation, rods of any shape may be installed.

**FEATURES**

- Stress free fastening
- Premeasured components in a sealed glass capsule
- High load capacity
- Suitable for reinforcing bars of any configuration
- Simple installation by hammering action only
- No angular-cut or pointed end required, installs with straight cut rebar and threaded rod
- Excellent resistance to vibration

**TYPICAL APPLICATIONS**

- Rebar and threaded rod dowelling
- Close spacing and edge distance applications
- Structural rehabilitation applications
- Replacement of damaged or incorrectly positioned cast-in anchors

**LIMITATIONS**

Not recommended for uncured concrete (less than 7 days of curing).

**MATERIAL SPECIFICATIONS**

**Hammer cap capsule**

- Quartz aggregate, hardener and resin

**Reinforcing bar**

- Conforms with CAN/CSA - G30.18-M92 (Supplied by others)

**Threaded rods**

- ASTM A 307 Grade 2 (UTS = 60,000 psi)
- ASTM A 193 Grade B7 (UTS = 125,000 psi)

**INSTALLATION**

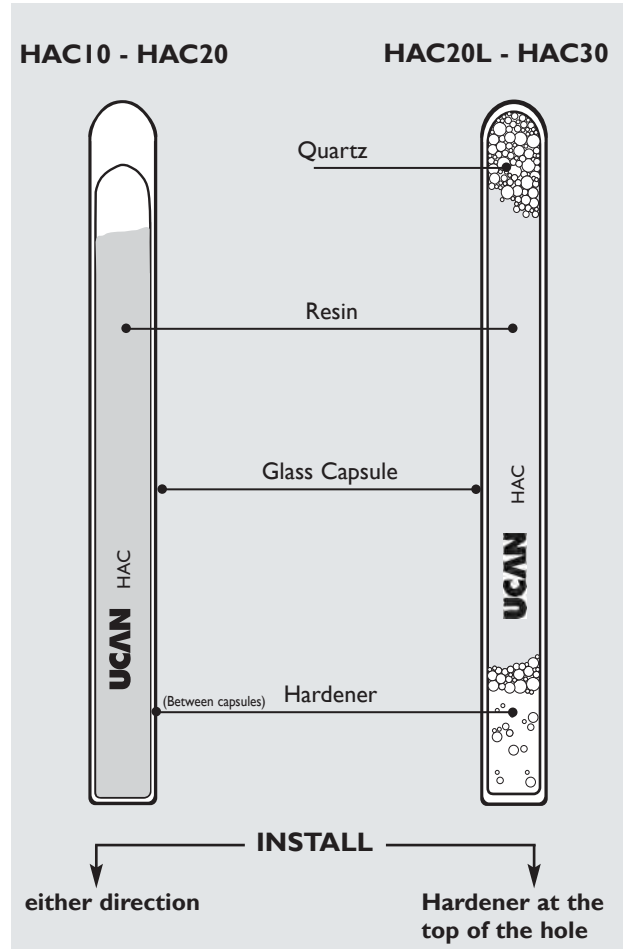
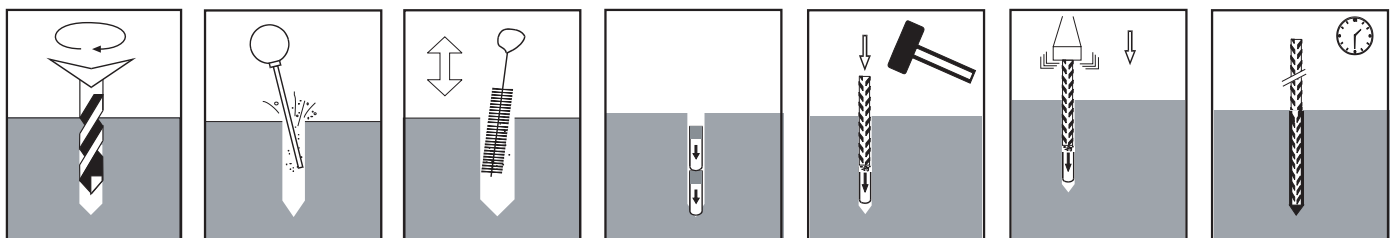

# HAMMER CAPSULE ADHESIVE ANCHOR

## CAPSULE SPECIFICATIONS

Capsule Data			
Part Number	Capsule		
	Diameter	Length	Volume
	inch	inch	cu. inch
HAC 10	7/16	3-1/4	0.33
HAC12	1/2	4	0.50
HAC16	11/16	5	1.21
HAC20	27/32	4-3/4	1.88
HAC20L	27/32	6-3/4	2.32
HAC24	15/16	8-1/4	3.99
HAC30	1-5/16	10-7/16	11.66

### Mechanical Properties (Cured Resin)

Bond Strength (in concrete)	7.3 MPa
Compressive Strength	160 MPa
Bending Strength	110 MPa
Tensile Strength	50 MPa

## CURING TIMES

Temperature	Dry Hole Installation	Damp Hole Installation
Over 20° C (over 68 F)	10 minutes	30 minutes
10° - 20° C (50 - 68° F)	20 minutes	1 hour
0° - 10° C (32 - 50° F)	1 hour	3 hours
-5° - 0° C (23-32° F)	5 hours	n/a

### Resistance against Chemicals

The resin compound in the chemical anchors is resistant to many chemicals. The tests were carried out in accordance with the ASTM C 581-87. For complete listing, see Appendix, 8.1 (Resistance to Chemicals) or please contact UCAN Technical Department.

**INSTALLATION SPECIFICATIONS**

Threaded Rod Dowelling					
Rod Size	Drilled Hole Diameter	Embedment Depth	Max. Installation Torque	Adhesive Required per inch Embedment	# of Hammer Caps Required
inch	inch	inch	ft. lbs	cu. inch/inch	
3/8	7/16	3-1/2	20	0.081	1 x HAC10
		7			2 x HAC10
1/2	9/16	4	30	0.110	1 x HAC12
		8			2 x HAC12
5/8	3/4	5	70	0.227	1 x HAC16
		10			2 x HAC16
3/4	7/8	5	150	0.284	1 x HAC20
		10-3/4			2 x HAC20
	1	6-3/4			1 x HAC20L
		13			2 x HAC20L
7/8	1	6-1/2	170	0.336	1 x HAC20L
		13			2 x HAC20L
1	1-1/8	8	210	0.418	1 x HAC24
		16			2 x HAC24
1-1/4	1-1/2	13	380	0.818	1 x HAC30
		26			2 x HAC30

**NOTE:**

- It is possible to combine capsules of different size in the hole to meet varied installation conditions (i.e. hole size and embedment). Contact UCAN to select the right capsule mix.
- To calculate the adhesive mortar volume required for a specific embedment, multiply the adhesive mortar volume listed above by the embedment required. Select the combination of capsules using the capsule volume chart. When selecting a combination of capsules, check the overall capsule length to be sure that it does not exceed the embedment depth and that the capsule diameter is smaller than the drilled hole size.

# HAMMER CAPSULE ADHESIVE ANCHOR



Rebar Dowelling					
Metric Rebar	Drilled Hole Diameter	Approx. Overall Rebar Diameter	Adhesive Required per inch Embedment	Embedment	# of Hammer Caps Required
	inch	inch	cu. inch/inch	inch	
10M	9/16	1/2	0.115	4	1 x HAC12
				8	2 x HAC12
15M	3/4	11/16	0.167	5	1 x HAC16
				10	2 x HAC16
20M	61/64	13/16	0.261	5	1 x HAC20
				7-1/4	1 x HAC20L
25M	1-1/4	1-1/16	0.540	14-1/2	2 x HAC20L
				8	1 x HAC24
				16	2 x HAC24
30M	1-1/2	1-5/16	0.782	14	1 x HAC30
				28	2 x HAC30
35M	1-3/4	1-1/2	0.814	14	1 x HAC30
				28	2 x HAC30

**NOTE:**

- Variation in rebar diameter and pattern may alter the capsule type and quantity required, as noted above. If necessary, capsules of different sizes may be mixed, hole diameter may be different than marked on the capsules.
- Before inserting the glass capsule, check the viscosity of the resin. At room temperature, resin should run easily inside the capsule.
- Always have the arrow pointing towards the bottom of the hole when inserting capsule(s) into the hole.
- Mark embedment depth on the rod / rebar, prior to insertion, and hammer it in until the mark is flush with the concrete surface.
- Capsule(s) must be fully inserted in the hole to ensure correct mixing. It is possible to use a mix of different sized capsules in the hole to meet varied installation conditions. Please consult the UCAN Technical Department for proper procedures and feasibility.
- Reinforcing bar data is in compliance with CAN/CSA - G30.18-M92 and RSIC design guidelines.

**NOTE:**

Apply Safety Factor to ensure the working load per anchor does not exceed 1/4 of the tabulated ultimate load, under static loading conditions.

**DESIGN DATA**

**Average Ultimate Tension Loads for installations Using Threaded Rods in 4,500 psi ( 31 MPa ) Concrete**

Rod Size	Drilled Hole		Hammer Cap required	Average Ultimate Tension Loads in min. 31 MPa Concrete					
	Dia.	Embedment		A307 Threaded Rod		A325 Threaded Rod		304 SS Threaded Rod	
	inch	inch		lbs	kN	lbs	kN	lbs	kN
3/8	7/16	3-1/2	1 x HAC10	4,650	20.68	5,083	22.61	5,083	22.61
		7	2 x HAC10	4,650	20.68	9,300	41.37	6,588	29.30
1/2	9/16	4	1 x HAC12	8,514	37.87	11,900	52.93	11,900	52.93
		8	2 x HAC12	8,514	37.87	17,028	75.74	10,643	47.34
5/8	3/4	5	1 x HAC16	13,560	60.32	14,524	64.61	14,524	64.61
		10	2 x HAC16	13,560	60.32	27,120	120.06	19,210	85.45
3/4	1	7/8	1 x HAC20	18,636	82.90	18,636	82.90	18,636	87.90
		6-3/4	1 x HAC20L	20,040	89.14	22,875	101.75	22,875	101.75
		13	2 x HAC20L	20,040	89.14	40,080	178.28	28,390	126.28
7/8	1	6-1/2	1 x HAC20L	23,238	103.37	23,238	103.37	23,238	103.37
		13	2 x HAC20L	27,720	123.30	50,349	223.96	39,270	174.68
1	1-1/8	8	1 x HAC24	34,854	155.04	34,854	155.04	34,854	155.04
		16	2 x HAC24	36,360	161.74	72,720	323.48	51,510	229.13
1-1/4	1-1/2	13	1 x HAC30	58,140	258.62	69,230	307.95	69,230	307.95
		26	2 x HAC30	58,140	258.62	116,280	517.24	82,365	366.38

**Average Ultimate Shear Loads for installations Using Threaded Rods in 4,350 psi ( 30 MPa ) Concrete**

Rod Size	Drilled Hole		Hammer Cap required	Average Ultimate Shear Loads in min. 30 MPa Concrete					
	Dia.	Min. Embedment		A307 Threaded Rod		A325 Threaded Rod		304 SS Threaded Rod	
	inch	inch		lbs	kN	lbs	kN	lbs	kN
3/8	7/16	3-1/2	1 x HAC10	2,790	12.41	5,580	24.82	3,953	17.58
1/2	9/16	4	1 x HAC12	5,108	22.72	10,217	45.45	7,237	32.19
5/8	3/4	5	1 x HAC16	8,136	36.19	16,272	72.38	11,526	51.27
3/4	7/8	5	1 x HAC20	12,024	53.49	24,048	106.97	17,034	75.77
7/8	1	6-1/2	1 x HAC20L	16,632	73.98	33,264	147.96	23,562	104.81
1	1-1/8	8	1 x HAC24	21,816	97.04	43,632	194.08	30,906	137.48
1-1/4	1-1/2	13	1 x HAC30	34,884	155.17	69,768	310.34	49,416	219.81

# HAMMER CAPSULE ADHESIVE ANCHOR

## Load Reduction Factors for Anchor Groups with Reduced Spacing and Edge Distances

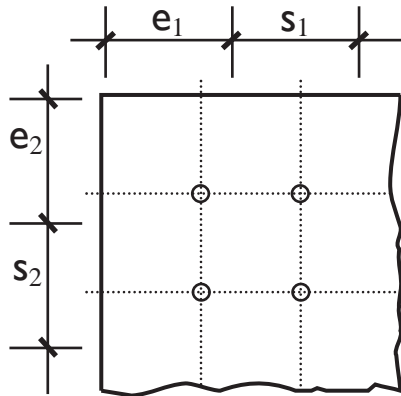

$(e_{min} = 0.5 \times e) < e < 1.0 \times h$		Reduction factor ( $f_e$ )
Recommended	$1.0 \times h$	1.00
Minimum	$0.5 \times h$	0.70
Reduced	Actual distance(s)	$0.6 \times e/h + 0.4$

$(s_{min} = 0.5 \times s) < s < 1.5 \times h$		Reduction factor ( $f_s$ )
Recommended	$1.5 \times h$	1.00
Minimum	$0.5 \times h$	0.70
Reduced	Actual distance(s)	$0.3 \times s/h + 0.55$

- h - embedment depth
- e - actual edge distance ( $e_1$ ;  $e_2$ ; etc.)
- s - actual center to center spacing ( $s_1$ ;  $s_2$ ; etc.)

The ultimate strength of a uniformly loaded anchor group is  $n$  (number of anchors in the group) times the strength of the most influenced anchor calculated as:

$$F_{(red)} = \{f_{s1} \times f_{s1} \times f_{s(n)} \times f_{e1} \times f_{e2} \times f_{e(n)}\} \times F_{ultimate}$$

## Average Ultimate Tension Loads for installations Using Metric Reinforcing Bars in 4,500 psi ( 31 MPa ) Concrete

Metric Rebar	Drilled Hole		Hammer Cap required	Average Ultimate Tension Loads in min. 4,500 psi (31 MPa) Concrete					
	Dia.	Embedment		300 MPa		400 MPa		500 MPa	
				inch	inch	lbs	kN	lbs	kN
10M	9/16	4	1 x HAC12	8,714	38.76	8,714	38.76	8,714	38.76
		8	2 x HAC12	9,105	40.50	12,140	54.00	15,175	67.50
15M	3/4	5	1 x HAC16	14,524	64.61	14,524	64.61	14,524	64.61
		10	2 x HAC16	18,210	81.00	24,280	108.00	29,048	129.21
20M	61/64	5	1 x HAC20	Grade 300R bars are normally available in sizes 10M and 15M	22,148	98.52	22,148	98.52	
		7-1/4	1 x HAC20L		25,840	114.94	25,840	114.94	
		14-1/2	2 x HAC20L		36,419	162.00	45,524	202.50	
25M	1-1/4	8	1 x HAC24		38,730	172.28	38,730	172.28	
		16	2 x HAC24		60,698	270.00	75,873	337.50	
30M	1-1/2	14	1 x HAC30		81,333	361.79	81,333	361.79	
		28	2 x HAC30		84,978	378.00	106,223	472.50	
35M	1-3/4	14	1 x HAC30		88,111	391.94	88,111	391.94	
		28	2 x HAC30		121,397	540.00	151,746	675.00	

## **| SPECIFICATION**

The following sample specification clause is arranged for inclusion in any one of a variety of master specification sections utilizing the Construction Specifications Canada (CSC) format. Brackets [...] indicate alternatives, data required, or the need to fill in information by the specifier.

### **ANCHORS (FASTENERS)**

[*Grade, size and length*] Reinforcing Bar Dowels (Threaded Rods) shall be installed into [*diameter*] hole with **UCAN Hammer Cap Capsules**, supplied by UCAN Fastening Products. The hole depth shall be [*xx mm*] and must contain [*quantity*] HAC [*size*] sealed glass capsules [*diameter and length*].

#### **Installation:**

Anchor holes shall be drilled with a drill bit conforming to ANSI B94.12-77 Standards. The mixing of the Hammer Cap adhesive capsule components shall be accomplished by driving the straight cut reinforcing bar (threaded rod) into the capsule without rotation by hand with a hammer or mechanically by using a percussion hammer and power driver head. The installation shall follow the manufacturer's instructions.

#### **Materials:**

The UCAN Hammer Cap adhesive Capsule shall be a two part capsule containing the resin and the hardener and shall bear the manufacturer name, size.

Reinforcing Bars shall conform to CAN / CSA -G30.18 - M92 Standards.

Threaded rods shall be manufactured from [*Grade X, ASTM XXX*] steel. The rod shall be protected against corrosion by zinc plating [*or by other means of coating which provides equivalent protection*] to the thickness of [*microns*].

**DESCRIPTION**

The UCAN FLO-ROK FR5 MAX anchoring system is an styrene free epoxy acrylate adhesive that incorporates the latest technology in chemical anchoring. The unique properties of the two component, high strength adhesive provide stress free anchoring and minimal shrinkage. It has reliable cure due to low mix ratio sensitivity and is ideal for use in a wide range of temperatures from -20°C to over 30°C. It is an excellent choice for anchoring and dowelling jobs. The special static mixing nozzle ensures thorough, 10:1 mixing of the resin and the hardener. The result is consistent, fast and complete curing every time. The FR5-28 MAX, a jumbo 28 oz cartridge, is the most economical size for large volume applications such as reinforcing bar dowelling.

**FEATURES**

- Fast set
- Broad working temperature range from -20°C to +30°C
- Stress free anchoring
- Minimal shrinkage
- Moisture insensitive, non sag formula
- Styrene free, low VOC; meets LEED guidelines
- Suitable for hollow wall applications

**TYPICAL APPLICATIONS**

- Hollow wall anchoring applications
- Rebar dowelling
- Telecommunications equipment
- Highway and bridge construction
- Renovations



**MATERIAL SPECIFICATIONS**

Anchor Component	Material Standard	Mechanical Properties	
		F <sub>u</sub>	F <sub>y</sub>
Standard threaded rod	ISO 898 Grade 5.8	500 MPa (72.5 ksi)	400 MPa (58 ksi)
High Strength threaded rod	ASTM A193 , Grade B7	862 MPa (125 ksi)	724 MPa (105 ksi)
Stainless steel threaded rod	ASTM F593 (AISI 304/316)	689 MPa (100 ksi)	448 MPa (65 ksi)
Carbon steel nuts	ASTM A563		
Stainless steel nuts	ASTM F 594		
Stainless and carbon steel washers	ANSI B18.22.1 Type A Plain		
Two component (10:1 mix ratio) acrylic epoxy adhesive in 28 oz.; 12 oz. twin cartridge; 10 oz and 5 oz. coaxial cartridge			
Corrosion protection (carbon steel anchors)	ASTM B633 - 98e1	0.0002" ( 5 micron)	electrodeposited

# FLO-ROK FR5MAX INJECTION ADHESIVE ANCHOR



## INSTALLATION

Details	Anchor size						
	3/8	1/2	5/8	3/4	7/8	1	1-1/4
Anchor rod dia. $d_a$ (in)	3/8	1/2	5/8	3/4	7/8	1	1-1/4
Drill bit / hole nominal diameter $d_o$ (in)	1/2	9/16	11/16	13/16	1	1-1/8	1-3/8
Effective embedment / hole depth $h_{ef}$ / (in)	3-1/2	4	5	6-1/2	n/a	8-1/4	11-3/4
Critical anchor spacing for 100% performance $s_{cr,N}$	10-1/2	12	15	19-1/2	n/a	24-3/4	35-1/4
Required edge distance for 100% performance $c_{cr,N}$	5-1/4	6	7-1/2	9-3/4	n/a	12-3/8	17-5/8
Minimum base material thickness $h_{min}$	1.0 x embedment + 2 inches						
Max. installation torque $T_{inst}$ (ft x lbf)	15	30	59	111	n/a	148	204

**Note:** Carbide tipped drill bits shall conform to ANSI B 212.15

• All dimensions are in inches

### SOLID CONCRETE/MASONRY APPLICATIONS

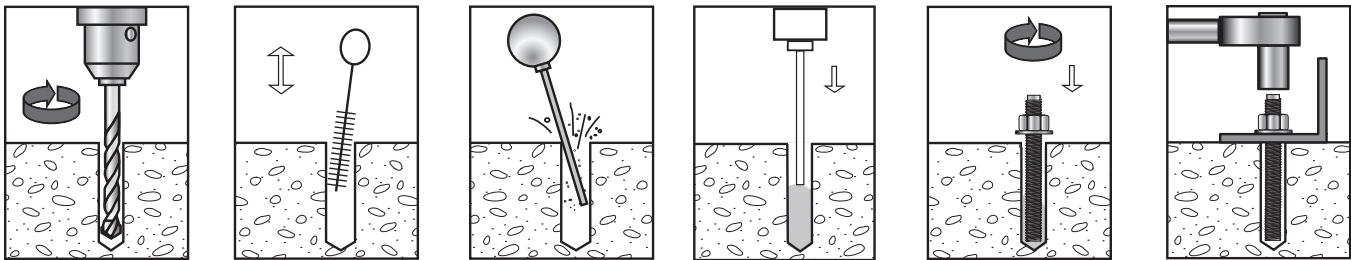

### HOLLOW CONCRETE BLOCK/MASONRY APPLICATIONS

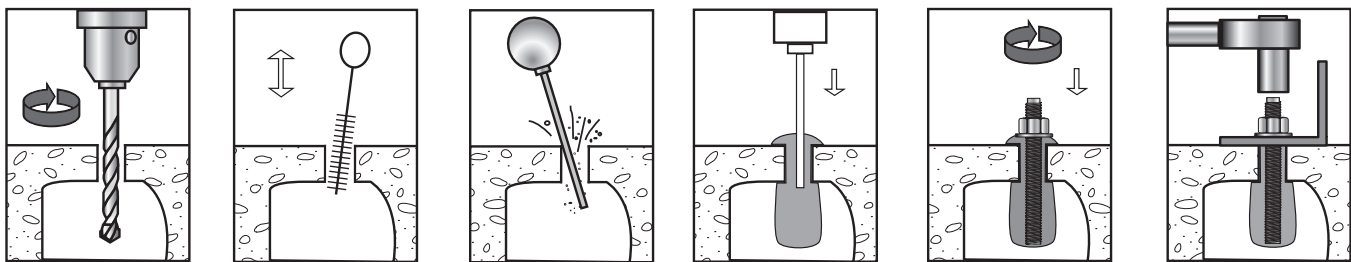

**NOTE:**

- Clean hole thoroughly by using nylon brush and blow-out bulb or compressed air (65 - 80 psi)
- Always dispense about 1 oz. FLO - ROK to the side, prior to injecting it into the clean hole, to assure uniform mixing indicated by a consistent dark grey colour.
- At a minimum, half fill the hole starting from the bottom up by slowly withdrawing the nozzle. (solid installation)  
Fill the screen fully starting from the bottom by slowly withdrawing the nozzle. (hollow installation)
- Mark embedment depth on the threaded rod (rebar) prior to insertion, and insert the rod (rebar) turning it slowly until it reaches the bottom of the hole ( depth mark is flush with the surface).
- Observe curing time. The installed anchor must not be disturbed or loaded before the specified curing time has elapsed.

**CURING TIMES**

Temperature	Gel Time	Full Cure
30° C (86°F)	4 min	35 minutes
20°C (68°F)	6min	50 minutes
5°C (41°F)	18min	145 minutes
-20°C (-4°F)	20 min*	24 hours

Do not disturb stud during the curing time

\*Cartridge temperature +5°C (41°F)

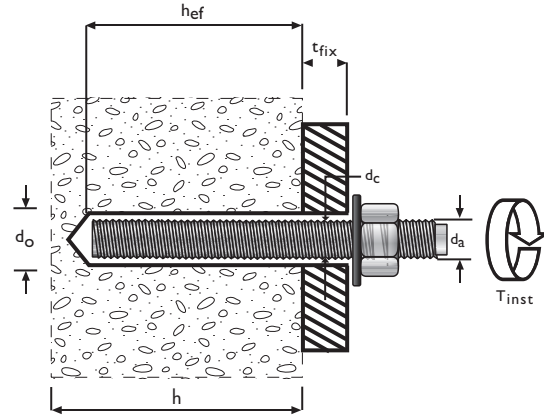
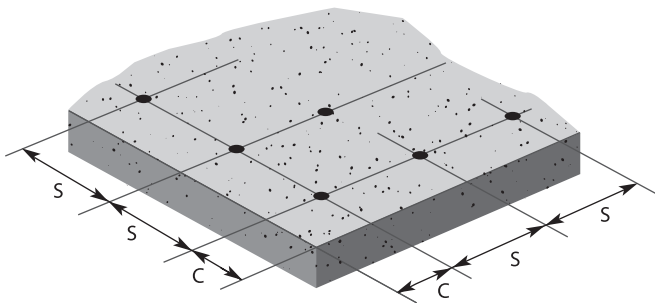

**DESIGN DATA**

**Allowable and Ultimate Bond Strength in min. 20 MPa (3000 psi) Concrete**

Rod Diameter inch	Hole Diameter inch	Embedment inch	Tension Bond Capacities in 3000 psi Concrete	
			Allowable Load lbs (kN)	Ultimate Load lbs (kN)
3/8	1/2	3	1,822 (8.1)	7,289 (32.4)
		4-1/2	2,733 (12.2)	10,934 (48.7)
1/2	9/16	4	3,010 (13.4)	12,038 (53.6)
		6	4,514 (20.1)	18,057 (80.3)
5/8	11/16	5	4,215 (18.8)	16,859 (75.0)
		7-1/2	6,322 (28.1)	25,289 (115.5)
3/4	13/16	6	6,700 (29.8)	26,799 (119.2)
		9	10,050 (44.7)	40,199 (178.8)
1	1-1/8	8	9,276 (41.3)	37,102 (165.1)
		12	13,913 (61.9)	55,653 (247.6)
1-1/4	1-3/8	10	11,467 (51.0)	45,869 (204.0)
		15	17,201 (76.5)	68,804 (306.0)

**Notes:** • Use the lesser value of bond and steel capacity

- All above data are calculated using independent laboratory test data on metric size anchor rods installed into local concrete
- Not recommended for overhead anchoring applications
- For flooded hole application suitability please contact Ucan Fastening Products

## FLO-ROK FR5MAX INJECTION ADHESIVE ANCHOR

### Ultimate Bond and Steel Strength for Metric Rebar Dowelling in Normal Weight Stone Aggregate Concrete

Metric Rebar Size	Hole Dia. inch	Embedment inch	Bond/Concrete Strength		Rebar Strength Properties (Grade 400)			
			30 MPa concrete		Yield Strength		Tensile Strength	
			lbf	kN	lbf	kN	lbf	kN
10M	9/16	1-1/4	3,343	14.87	8,992	40	12,140	54
		3-1/2	9,595	42.68				
		7	19,191	85.36				
15M	3/4	2-1/2	9,130	40.61	17,985	80	24,279	108
		5-1/2	20,087	89.35				
		10	36,521	162.45				
20M	61/64	3-1/2	15,507	68.98	26,977	120	36,419	162
		6-1/2	30,164	134.18				
		14	64,968	288.99				
25M	1-1/4	4	18,747	83.39	44,962	200	60,698	270
		8-1/2	51,738	230.14				
		16	97,389	433.21				
30M	1-1/2	5	25,813	114.82	62,947	280	84,978	378
		10	73,042	324.91				
		20	146,084	649.81				
35M	1-3/4	5	25,813	114.82	89,924	400	121,397	540
		10	85,216	379.06				
		20	170,431	758.12				
45M	2-1/4	5	25,813	114.82	134,885	600	182,095	810
		10	3,009	324.76				
		20	211,475	940.69				

**Notes:**

- 1./ Ultimate bond values are developed using data for threaded rods of comparable sizes.
- 2./ Rebar strength properties are based on nominal cross section of the rebar and minimum steel strength.
- 3./ Use the lesser value of bond and rebar strength.

**Allowable Steel Strength for Carbon and Stainless Steel Threaded Rods**

Size	ISO 898 Grade 5.8		B7 (125 ksi)		303/304 (100 / 85 ksi)		316 (100 / 85 ksi)	
	Tensile	Shear	Tensile	Shear	Tensile	Shear	Tensile	Shear
1/4	1,175	605	2,025	1,043	1,620	834	1,620	834
3/8	2,643	1,362	4,556	2,347	3,645	1,878	3,645	1,878
1/2	4,699	2,421	8,099	4,172	6,480	3,338	6,480	3,338
5/8	7,342	3,782	12,655	6,519	10,124	5,216	10,124	5,216
3/4	10,752	5,446	18,224	9,388	12,392	6,384	12,392	6,384
7/8	14,390	7,413	24,804	12,778	16,867	8,689	16,867	8,689
1	18,795	9,682	32,398	16,690	22,030	11,349	22,030	11,349
1-1/4	29,367	15,128	50,621	26,078	34,423	17,733	34,423	17,733

Allowable Tension and Shear load data shown are based on AISC Manual of Steel Construction (ASD) 9th Edition

**Ultimate Steel Strength for Carbon and Stainless Steel Threaded Rods**

Size	ISO 898 Grade 5.8		B7 (125 ksi)		303/304 (100 / 85 ksi)		316 (100 / 85 ksi)	
	Tensile	Shear	Tensile	Shear	Tensile	Shear	Tensile	Shear
1/4	2,670	1,602	4,602	2,454	3,682	1,963	3,682	1,963
3/8	6,007	3,604	11,354	5,522	8,283	4,418	8,283	4,418
1/2	10,679	6,407	18,408	9,817	14,726	7,854	14,726	7,854
5/8	16,686	10,011	28,762	15,340	23,010	12,272	23,010	12,272
3/4	24,027	14,416	41,417	22,089	28,164	15,021	28,164	15,021
7/8	32,704	19,622	56,374	30,066	38,334	20,445	38,334	20,445
1	42,715	25,629	73,631	39,270	50,069	26,704	50,069	26,704
1-1/4	66,743	40,046	115,049	61,359	78,233	41,724	78,233	41,724

Ultimate Tension and Shear load data shown are based on AISC Manual of Steel Construction (LRFD) 3rd Edition

## FLO-ROK FR5MAX INJECTION ADHESIVE ANCHOR

### Allowable and Ultimate Load Data in Hollow Concrete Block

Rod Dia.	Hole Dia.	Screen Length	Installation Torque	Allowable Loads				Ultimate Loads			
				Tension		Shear		Tension		Shear	
inch	inch	inch	ft. lbs	lbf	kN	lbf	kN	lbf	kN	lbf	kN
3/8	1/2	3	10	360	1.60	803	3.56	1,800	8.00	3,200	14.23
		6									
1/2	5/8	3	15	490	2.18	1,005	4.47	2,450	10.90	4,020	17.88
		6									
5/8	3/4	6	20	490	2.18	1,238	5.50	2,450	10.90	4,950	22.04
		10									

### Load Adjustment Factors Spacing and Edge Distance

Embedment	Reduction Factors - TENSION -			
	2 x embedment		0.5 x embedment (min)	
	spacing	edge distance	spacing	edge distance
8 d <sub>a</sub> - 12 d <sub>a</sub>	1.00	1.00	0.63	0.67

### Concrete Factors

Concrete Strength (MPa)	Factor
30	1.04
40	1.07
50	1.09

**EPOXY USAGE ESTIMATING TABLES**

**Holes per FR5MAX-5**

Rod dia.	Hole dia.	Embedment (inch)											
		1	2	3	4	5	6	7	8	9	10	15	20
1/4	5/16	151.0	75.5	50.3	37.8	30.2	25.2	21.6	18.9	16.8	15.1	10.1	7.6
	3/8	89.4	44.7	29.8	22.3	17.9	14.9	12.8	11.2	9.9	8.9	6.0	4.5
3/8	7/16	91.1	45.6	30.4	22.8	18.2	15.2	13.0	11.4	10.1	9.1	6.1	4.6
	1/2	58.5	29.3	19.5	14.6	11.7	9.8	8.4	7.3	6.5	5.9	3.9	2.9
1/2	9/16	65.8	32.9	21.9	16.4	13.2	11.0	9.4	8.2	7.3	6.6	4.4	3.3
	5/8	42.3	21.2	14.1	10.6	8.5	7.1	6.0	5.3	4.7	4.2	2.8	2.1
5/8	11/16	48.1	24.0	16.0	12.0	9.6	8.0	6.9	6.0	5.3	4.8	3.2	2.4
	3/4	32.9	16.5	11.0	8.2	6.6	5.5	4.7	4.1	3.7	3.3	2.2	1.6

**Holes per FR5MAX-10**

Rod dia.	Hole dia.	Embedment (inch)											
		1	2	3	4	5	6	7	8	9	10	15	20
1/4	5/16	302.1	151.1	100.7	75.5	60.4	50.4	43.2	37.8	33.6	30.2	20.1	15.1
	3/8	178.8	89.4	59.6	44.7	35.8	29.8	25.5	22.4	19.9	17.9	11.9	8.9
3/8	7/16	182.4	91.2	60.8	45.6	36.5	30.4	26.1	22.8	20.3	18.2	12.2	9.1
	1/2	117.1	58.5	39.0	29.3	23.4	19.5	16.7	14.6	13.0	11.7	7.8	5.9
1/2	9/16	131.6	65.8	43.9	32.9	26.3	21.9	18.8	16.5	14.6	13.2	8.8	6.6
	5/8	84.7	42.4	28.2	21.2	16.9	14.1	12.1	10.6	9.4	8.5	5.6	4.2
5/8	11/16	96.2	48.1	32.1	24.1	19.2	16.0	13.7	12.0	10.7	9.6	6.4	4.8
	3/4	65.9	33.0	22.0	16.5	13.2	11.0	9.4	8.2	7.3	6.6	4.4	3.3
3/4	13/16	77.2	38.6	25.7	19.3	15.4	12.9	11.0	9.7	8.6	7.7	5.1	3.9
	7/8	54.5	27.3	18.2	13.6	10.9	9.1	7.8	6.8	6.1	5.5	3.6	2.7
7/8	61/64	67.1	33.5	22.4	16.8	13.4	11.2	9.6	8.4	7.5	6.7	4.5	3.4
	1	44.5	22.3	14.8	11.1	8.9	7.4	6.4	5.6	4.9	4.5	3.0	2.2

**Holes per FR5MAX-12**

Rod dia.	Hole dia.	Embedment (inch)											
		1	2	3	4	5	6	7	8	9	10	15	20
1/4	5/16	377.5	188.8	125.8	94.4	75.5	62.9	53.9	47.2	41.9	37.8	25.2	18.9
	3/8	223.5	111.7	74.5	55.9	44.7	37.2	31.9	27.9	24.8	22.3	14.9	11.2
3/8	7/16	227.9	113.9	76.0	57.0	45.6	38.0	32.6	28.5	25.3	22.8	15.2	11.4
	1/2	146.3	73.2	48.8	36.6	29.3	24.4	20.9	18.3	16.3	14.6	9.8	7.3
1/2	9/16	164.5	82.2	54.8	41.1	32.9	27.4	23.5	20.6	18.3	16.4	11.0	8.2
	5/8	105.9	52.9	35.3	26.5	21.2	17.6	15.1	13.2	11.8	10.6	7.1	5.3
5/8	11/16	120.2	60.1	40.1	30.1	24.0	20.0	17.2	15.0	13.4	12.0	8.0	6.0
	3/4	82.4	41.2	27.5	20.6	16.5	13.7	11.8	10.3	9.2	8.2	5.5	4.1
3/4	13/16	96.5	48.3	32.2	24.1	19.3	16.1	13.8	12.1	10.7	9.7	6.4	4.8
	7/8	68.1	34.1	22.7	17.0	13.6	11.4	9.7	8.5	7.6	6.8	4.5	3.4
7/8	61/64	83.8	41.9	27.9	21.0	16.8	14.0	12.0	10.5	9.3	8.4	5.6	4.2
	1	55.7	27.8	18.6	13.9	11.1	9.3	8.0	7.0	6.2	5.6	3.7	2.8

## FLO-ROK FR5MAX INJECTION ADHESIVE ANCHOR

### EPOXY USAGE ESTIMATING TABLES

Holes per FR5MAX-28

Rod dia.	Hole dia.	Embedment (inch)											
		1	2	3	4	5	6	7	8	9	10	15	20
1/4	5/16	891.9	446.0	297.3	223.0	178.4	148.7	127.4	111.5	99.1	89.2	59.5	44.6
	3/8	27.9	264.0	176.0	132.0	105.6	88.0	75.4	66.0	58.7	52.8	35.2	26.4
3/8	7/16	538.3	269.2	179.4	134.6	107.7	89.7	76.9	67.3	59.8	53.8	35.9	26.9
	1/2	345.6	172.8	115.2	86.4	69.1	57.6	49.4	43.2	38.4	34.6	23.0	17.3
1/2	9/16	388.5	194.3	129.5	97.1	77.7	64.8	55.5	48.6	43.2	38.9	25.9	19.4
	5/8	250.1	125.0	83.4	62.5	50.0	41.7	35.7	31.3	27.8	25.0	16.7	12.5
5/8	1 1/16	284.0	142.0	94.7	71.0	56.8	47.3	40.6	35.5	31.6	28.4	18.9	14.2
	3/4	194.6	97.3	64.9	48.7	38.9	32.4	27.8	24.3	21.6	19.5	13.0	9.7
3/4	13/16	228.0	114.0	76.0	57.0	45.6	38.0	32.6	28.5	25.3	22.8	15.2	11.4
	7/8	161.0	80.5	53.7	40.2	32.2	26.8	23.0	20.1	17.9	16.1	10.7	8.0
7/8	61/64	198.0	99.0	66.0	49.5	39.6	33.0	28.3	24.7	22.0	19.8	13.2	9.9
	1	131.5	65.7	43.8	32.9	26.3	21.9	18.8	16.4	14.6	13.1	8.8	6.6
1	1 1/16	143.9	72.0	48.0	36.0	28.8	24.0	20.6	18.0	16.0	14.4	9.6	7.2
	1 1/8	108.1	54.1	36.0	27.0	21.6	18.0	15.4	13.5	12.0	10.8	7.2	5.4
1 1/4	1 3/8	83.7	41.9	27.9	20.9	16.7	14.0	12.0	10.5	9.3	8.4	5.6	4.2
	1 1/2	55.0	27.5	18.3	13.8	11.0	9.2	7.9	6.9	6.1	5.5	3.7	2.8
Rebar size													
10M	9/16	391.6	195.8	130.5	97.9	78.3	65.3	55.9	49.0	43.5	39.2	26.1	19.6
15M	3/4	268.4	134.2	89.5	67.1	53.7	44.7	38.3	33.6	29.8	26.8	17.9	13.4
20M	61/64	173.8	86.9	57.9	43.4	34.8	29.0	24.8	21.7	19.3	17.4	11.6	8.7
25M	1 1/4	84.7	42.3	28.2	21.2	16.9	14.1	12.1	10.6	9.4	8.5	5.6	4.2
30M	1 1/2	58.8	29.4	19.6	14.7	11.8	9.8	8.4	7.3	6.5	5.9	3.9	2.9
35M	1 3/4	48.3	24.2	16.1	12.1	9.7	8.1	6.9	6.0	5.4	4.8	3.2	2.4

For correct epoxy usage, add 20% waste (multiply the tabulated number by 0.80)

**DESCRIPTION**

FLO-ROK FRG is a fast setting, high strength, hydraulic type anchoring cement. As it hardens, it expands to fill voids and develops 2000 psi compressive strength in 2 hours at room temperature. Controlled water additions allow the product to be used in packable (vertical) or pourable (horizontal) applications. To ensure optimal performance of FRG, the hole diameter should be at least 1" (25 mm) larger than the post being fastened. The minimum recommended embedment is 2" (50 mm).

**TYPICAL APPLICATIONS**

- Anchoring of wood or metal sign posts, fence posts, parking meters
- Dowel and rod installation
- Handrail installation
- Setting appliances, machinery and processing equipment
- Door stops
- Ornamental ironwork installation

**LIMITATIONS**

- Hot temperature will speed up setting
- At colder temperatures, below 10 °C (50 °F) use warm water
- Do not apply over surfaces that are frozen or contain frost.

**FEATURES**

- High strength, rapid-setting material
- Suitable for horizontal and vertical applications ( controlled water additions)
- Gray color
- As it hardens, it expands to fill voids
- Non corrosive, non rusting, waterproof

**MATERIAL SPECIFICATIONS**

**Composition and Materials:** FRG Anchoring Cement is a combination of special cements and silica sand

**Yield:** 50 lbs pail (22.7 kg) will yield 0.42 cu.ft (0.012m<sup>3</sup>) mixed anchoring material

**Color:** Grey

**Sizes:** 11.9 lbs (FRG-12) and 50 lbs (FRG-50)

**Physical Properties:** Setting time: (ASTM C 191)  
 Final set – 10 to 30 min.



Compressive Strength (ASTM C109)	
2 hrs.	2,000 psi (13.8 MPa)
24 hrs.	4,000 psi (27.6 MPa)
7 days	6,000 psi (41.4 MPa)
28 days	7,000 psi (48.3 MPa)